

EE36 Series

Transmitters for Moisture Content in Oil

E+E Transmitter Series EE36 are specially designed for the measurement of water content in oil. EE36 is ideal for online monitoring of moisture in lubrication or insulation oil, which is very important for the long-term performance and adaptive maintenance of plant and machinery. For instance, moisture affects dramatically the insulation characteristics of electrical transformer oil and therefore continuous monitoring is extremely important.

Humidity measurement in oil

Similar to the humidity in the air, the water content in an oil can be described by the absolute value in ppm or by the relative value a_w :

- ppm (mass of water / mass of oil)
- a_w (actual water content as fraction of the water content in the saturated oil)



$a_w = 0$ corresponds to water-free oil, while $a_w = 1$ describes fully saturated oil. a_w measurement with EE36 transmitter series is based on the outstanding long term stability and resistance to pollution of the E+E capacitive sensor elements series HC.

Product Versions

The physical quantities measured are water activity a_w and temperature T. With these quantities EE36 calculates the water content (ppm) in mineral transformer oils. Calculation of water content in non-mineral transformer oils and lubrication oils can be accomplished by downloading specific parameters of the oil. The measured and the calculated values are available on two free scaleable and configurable analogue outputs. In addition, an optional relay output can be used for alarms and process control.

Installation

The sensing probe is designed for inline monitoring and can be placed directly in the oil, at pressures up to 10bar (145psi). In addition to direct mounting of the sensing probe, a ball valve installation provides mounting and removal of the probe without interrupting the process.

Easy Calibration and Adjustment of EE36

The user can easily readjust or calibrate the transmitter by using either a simple procedure with two push buttons on the printed circuit board or the configuration software.

Software Tools

The configuration software is included in the scope of supply and allows an easy and fast configuration of the analogue outputs and of the alarm and control thresholds. Further features of the configuration software are adjustment and calibration of the outputs and service operations such as replacement of the sensing elements or of the entire sensing probe.

Features of EE36

Measurement of a_w and T at pressure up to 10bar (145psi)	✓
Calculation of water content in ppm for mineral transformer oil	✓
Two free scaleable and configurable analogue outputs	✓
Probe cable length up to 10m (32.8ft)	✓
Easy on site adjustment and calibration of a_w and T outputs	✓
LED indication for operation and sensing probe status	✓
User configuration of the instrument with PC via RS232 interface	✓
Configuration software	✓
Display of a_w , T and water content with MIN/MAX function	optional
Two free configurable relays outputs	optional
Replaceable sensing probe	optional
Connector for power supply and outputs	optional

Housing Dimensions (mm)

Installation Example

Housing:

polycarbonate housing

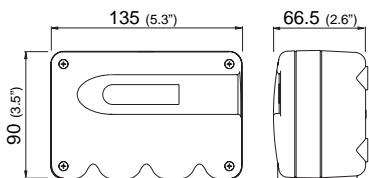

metal housing

NEW

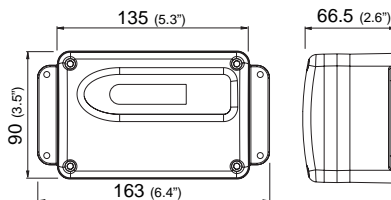

For use in harsh industrial environments the EE36 series is available in a robust metal housing.

Model:

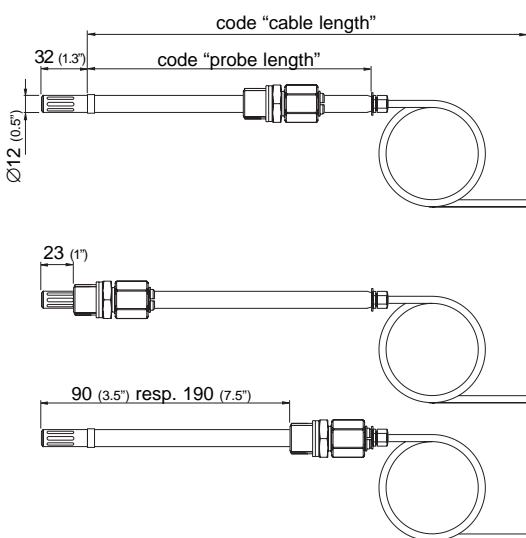

EE36-xEx

Remote probe for T -40...180°C (-40...356°F)
and pressure-tight up to 10bar (145psi)
probe material: stainless steel

minimum installation depth

maximum installation depth

ball valve installation (pressure-tight up to 10bar/145psi)

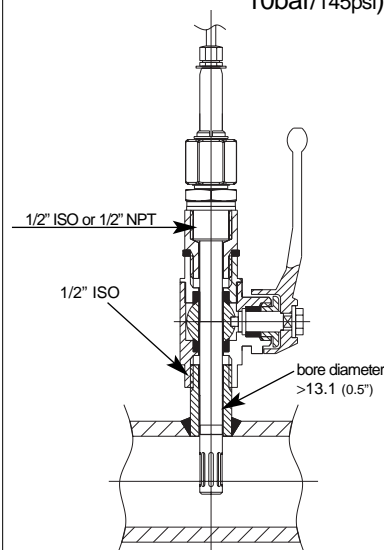

fixed installation (pressure-tight up to 10bar/145psi)

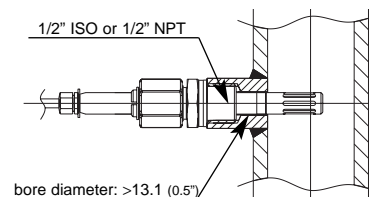

Connection Versions

Standard

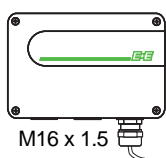

transmitter	1xM16
transmitter incl. alarm output	2xM16

Plug Option C03

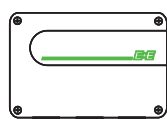

Lumberg RKC 5/7
power supply + analogue output

Plug Option C07

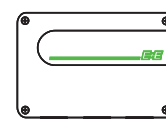

Lumberg RSC 5/7
RS232
Lumberg RKC 5/7
power supply + analogue output

Connection Diagram

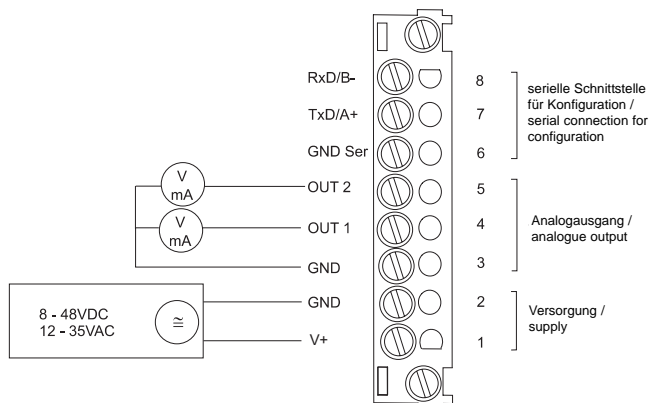

Terminal configuration - Alarm output

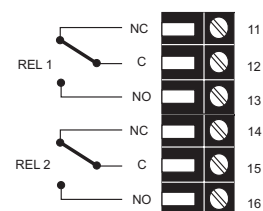

Technical Data

Measuring values

Water activity

Water activity sensor ¹⁾	HC1000-400	
Measuring range ¹⁾	0...1a _w	
Accuracy incl. hysteresis and nonlinearity in air		
- Special calibration against certified standards	± 0.01a _w (0...0.9a _w)	± 0.02a _w (0.9...1a _w)
- Standard calibration	± 0.02a _w (0...0.9a _w)	± 0.03a _w (0.9...1a _w)
Temperature dependence of electronics	typ. ± 0.0001 [1/°C]	(typ. ± 5.6 * 10 ⁻⁵ [1/°F])
Temperature dependence of sensing probe	typ. ± (0.00002 + 0.0002 x a _w) x ΔT [°C]	ΔT = T - 20°C
Response time with stainless steel filter at 20°C / t ₉₀	typ. 10min in still oil	

Temperature

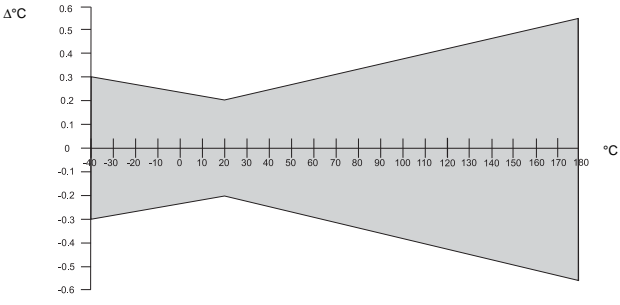
Temperatur sensor element	Pt1000 (tolerance class A, DIN EN 60751)	
Working range sensing probe	-40...180°C (-40...356°F)	
Accuracy (typ.)		

Temperature dependence of electronics	typ. ± 0.005°C/°C	
---------------------------------------	-------------------	--

Outputs²⁾

Two freely selectable and scaleable analogue outputs	0 - 5V	-1mA < I _L < 1mA
	0 - 10V	-1mA < I _L < 1mA
	4 - 20mA	R _L < 500 Ohm
	0 - 20mA	R _L < 500 Ohm

Adjustable measurement range²⁾

		from	up to	units
Water activity	a _w	0	1	
Temperature	T	-40 (-40)	180 (356)	°C (°F)
Water content ³⁾	x	0	1000	ppm

General

Supply voltage	SELV 8...48V DC SELV 12...35V AC			SELV = Safety Extra Low Voltage
Current consumption - 2x voltage output - 2x current output	for 24V DC/AC: typ. 40mA typ. 80mA			
Pressure range sensing probe	0.01...10bar (0.15...145psi)			
System requirements for software	WINDOWS 98 or later; serial interface			
Serial interface for configuration ⁴⁾	RS232C			
Housing / Protection class	PC or Al Si 9 Cu 3 / IP65; Nema 4			
Cable gland	M16 x 1.5 cable Ø 4.5 - 10 mm (0.18 - 0.39")			
Electrical connection	screw terminals up to max. 1.5mm ² (AWG 16)			
Sensor protection	stainless steel filter			
Operating temperature range of electronics	-40...60°C (-40...140°F)			
Working and storage temperature range				
Housing with display	-20...50°C (-4...122°F)			
Storage temperature	-40...60°C (-40...140°F)			
Electromagnetic compatibility according to	EN61000-6-2	EN 61000-6-3	ICES-003 ClassB	
	EN 61326-1+A1+A2		FCC Part15 ClassB	

Options

Display	graphical LCD (128x32 pixels), with integrated push-buttons for selecting parameters and MIN/MAX function	
Alarm outputs	2 x 1 switch contact: 250V AC / 6A and 28V DC / 6A threshold + hysteresis can be adjusted with configuration software	
Switching parameters (freely selectable)	a _w	Water activity
	T	Temperature
	x	Water content

¹⁾ refer to the working range of the humidity sensor.

²⁾ can be easily changed by software

³⁾ ppm output is valid in the range 0...100°C (32...212°F)

⁴⁾ no data output

Ordering Guide

EE36-

Hardware Configuration					
Housing	metal housing polycarbonate housing			M P	
Type	pressure tight			E	
Cable length (incl. probe length)	1m (3.3ft) 2m (6.6ft) 5m (16.4ft) 10m (32.8ft)			01 02 05 10	
Probe length	100mm (3.9") 200mm (7.9")			3 5	
Pressure-tight feedthrough	1/2" male thread 1/2" NPT thread			HA03 HA07	
Display	without display with display			D05	
Alarm output ¹⁾	without relay with relay			SW	
Plug	cable thread 1 plug for power supply and output 2 plugs for power supply/outputs and RS232			C03 C07	
Sensing probe	fixed interchangeable			P01	
Software Configuration					
Physical parameters of outputs	Temperature Water activity Water content in mineral transformer oil Water content in lubrication or non-mineral transformer oil ²⁾	T aw x x	[°C / °F] [] [ppm] [ppm]	(B) (K) (L) (M)	Output 1 Output 2
Type of output signals	0-5V 0-10V 0-20mA 4-20mA		(2) (3) (5) (6)		select according to Ordering Guide (2,3,5,6)
Temperature unit	°C °F				E01
Scaling of T-output in °C or °F	-40...60 (T02) 0...50 (T04) 0...100 (T05) -30...70 (T08) -20...120 (T10) -40...120 (T12)	-20...100 (T14) 0...120 (T16) 0...80 (T21) -20...80 (T24) -40...160 (T33) -40...250 (T81)	-40...140 (T83) 0...250 (T88) 32...120 (T90) 32...140 (T91) 32...250 (T94) 32...132 (T96)		Output T select according to Ordering Guide (Txx) other T-scaling refer to page 11
ppm Range x	0...100ppm (X01) 0...500ppm (X02) 0...1000ppm (X03)				Output x select according to Ordering Guide (X01 - X03)

1) Alarm output only available with cable glands but not with plugs!
2) input of oil specific parameters necessary

Accessories / Replacement Parts

(For further information see data sheet "Accessories")

- Stainless steel filter	(HA010110)	- Sealing element	(HA050309)
- Display + housing cover in metal	(D05M)	- Calibration set	(HA0104xx)
- Display + housing cover in polycarbonate	(D05P)	- Interface cable	(HA010301)
- Replacement probe	(Pxx)	- Ball valve set	(HA050101)
- Humidity sensor	(FE10)	- Bracket for installation onto mounting rails	(HA010203)

Order Example

EE36-PE055HA03SWC07P01/BL3-T08-X01

Housing:	polycarbonate housing	Output 1:	T
Type:	pressure tight	Output 2:	x (mineral transformer oil)
Cable length:	5m (16.4ft)	Output Signal:	0-10V
Probe length:	200mm (7.9")	Temperature unit:	°C
Pressure-tight feedthrough:	1/2" male thread	Scaling of T-output:	-30...70°C
Display:	without display	Water content x:	0...100ppm
Alarm output:	with relay		
Plug:	2 plugs for power supply/outputs and RS232		
Sensing probe:	interchangeable		

EE36: